

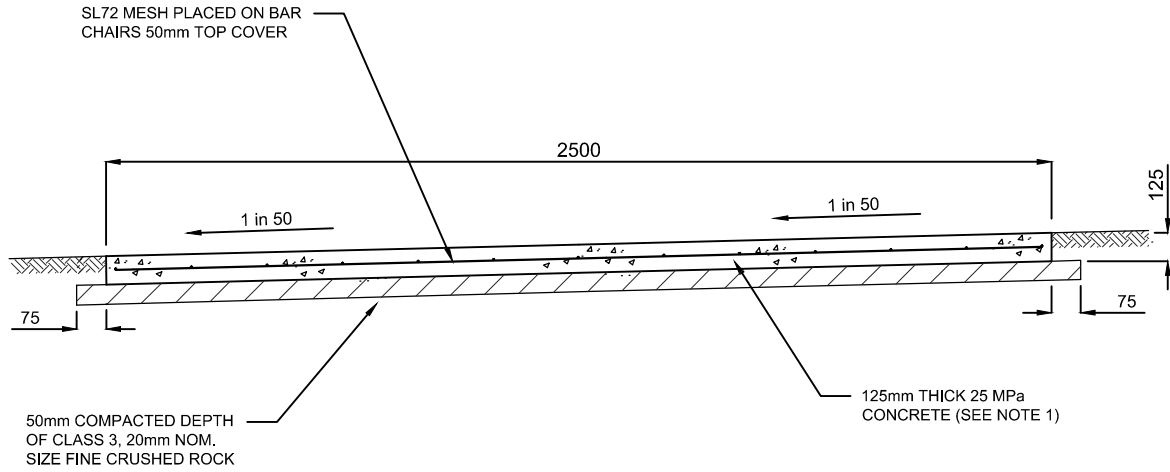

Drawing name: M:\Engineering Services\ARD - CAD - 3D\RESOURCE References\WCC Standard Drawings\SD2-3 Rev D.dwg (01 May, 2013)



### SHARED FOOTPATH

**NOTES :**

1. CONCRETE STRENGTH IS 25MPa AT 28 DAYS.
2. COUNCIL'S PRAM CROSSING DETAIL TO BE USED AT ROADWAYS ( SEE SD3-1 ).
3. CONCRETE TO BE LIGHT BROOM FINISH WITH EDGES NEATLY TOOLED AFTER THE BROOM IS APPLIED.
4. SHARED PATH TO HAVE 30mm DEEP SAWCUT JOINTS AT 2.5 METRE CENTRES ( NO TOOLED JOINTS ) AND EXPANSION JOINTS AT 12 METRES MAX. ( REFER TO SD2-4 FOR DETAILS ).
5. ALL SURFACES MUST COMPLY WITH AS4586 - SLIP RESISTANCE CLASSIFICATION OF NEW PEDESTRIAN SURFACE MATERIALS.
6. ANY EXPOSED AGGREGATE SURFACE FINISH IS TO BE ACHIEVED BY SANDBLASTING AFTER AT LEAST 48 HOURS CURING TIME.
7. N12mm Ø DEFORMED BARS AT 300mm CENTRES TO JOIN OLD CONCRETE TO NEW WHEN REINSTATING BROKEN FOOTPATH OR AS DIRECTED BY COUNCIL OFFICER.
8. EXPANSION JOINTS TO BE CONSTRUCTED AT 12m MAX. CTRS. AND ONE BAY EITHER SIDE OF VEHICLE CROSSINGS. REFER TO SD2-4 FOR DETAIL.
9. WHERE PERMISSION IS GRANTED TO USE COLOURED CONCRETE STRENGTH TO BE 32MPa.

Rev	Amendments	Approved	Date	 <b>WYNDHAM</b> CITY COUNCIL	SHARED PATH (ALL LOCATIONS)		Cad File : SD2-3.DWG
B	Edited Notes 01 & 03. Minor drafting modifications.		20-06-07				
C	Added Note 9.		01-09-09				Revision : D
D	Edited grading & mesh.		05-04-13				Drawing No.
					Engineering Services Approval No.: ES002	Date : 01/09/09	SD2-3

**GENERAL NOTES:**

- DRAWINGS ARE NOT TO SCALE.
- ALL MEASUREMENTS ARE IN MILLIMETERS UNLESS OTHERWISE STATED.
- FOR UP TO DATE DRAWINGS PLEASE CHECK WYNDHAM CITY COUNCIL WEB SITE.
- ALL STANDARD DRAWINGS TO BE USED IN CONJUNCTION WITH SD1-1 (STANDARD DRAWINGS CONDITIONS OF USE).